

10-2421...
LUFTPLATTENTRIMMER
AIRPLATE TRIMMER

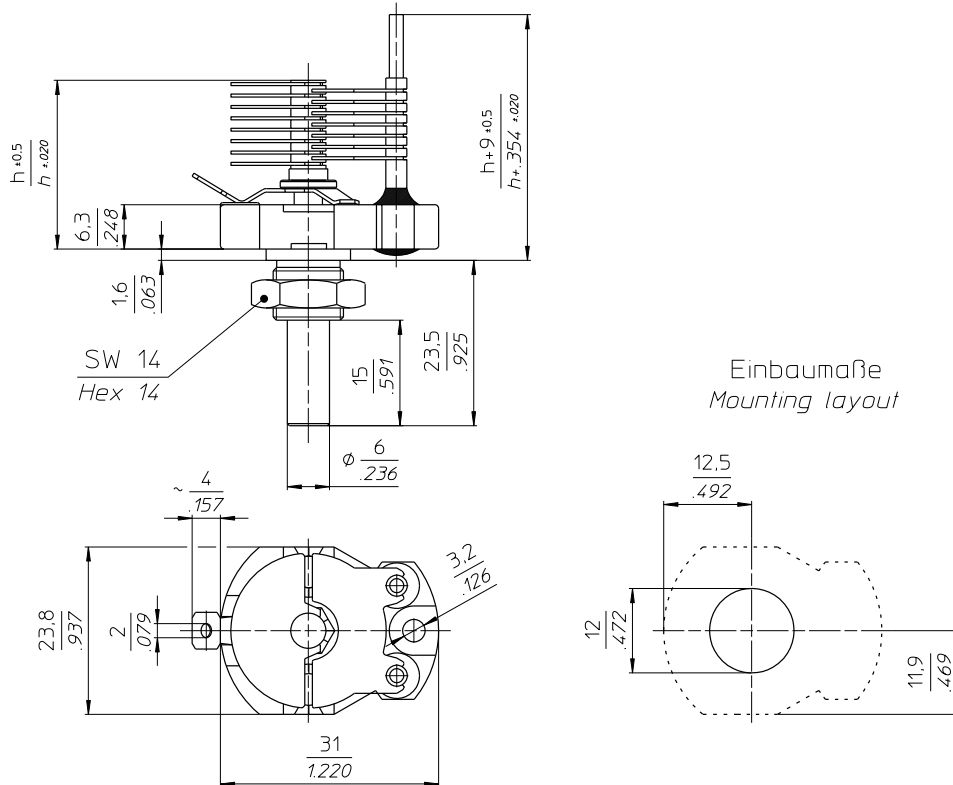

TECHNISCHE MERKMALE UND DATEN / TECHNICAL DATA

EINSTELLDREHMOMENT <i>TUNING TORQUE</i>	3,0 - 10,0 Ncm <i>4.2 - 13.9 in.oz.</i>	KERAMIK <i>CERAMIC</i>	DIN 40685 / 221 , silikonisiert <i>DIN 40685 / 221 , siliconized</i>
Q-FAKTOR <i>Q-FACTOR</i>	> 5000 bei 1 MHz <i>> 5000 @ 1 MHz</i>	DIELEKTRIKUM <i>DIELECTRIC</i>	Luft <i>Air</i>
BETRIEBSTEMPERATUR <i>OPERATING TEMPERATURE</i>	-65°C ... +125°C <i>-65°C ... +125°C</i>		

STANDARD - AUSFÜHRUNGEN / STANDARD CONFIGURATIONS

Teile - Nr. <i>Part - No.</i>	C _{min} [pF]	C _{max} [pF]	Plattenzahl No. Of Plates Stator / Rotor	Luftspalt Air Gap [mm]	Prüfspannung Test Voltage [-V _{eff}]	R _{isol.} R _{insul.} [MΩ]	TK _c [ppm/°C]	Höhe h Height h [mm]	Gewicht Weight [ca. g]
10-2421-40020-000	3,5	23,0	3 / 4	0,40	750	> 10 ³	45 ± 30	18,9	27,0
10-2421-40050-000	4,5	50,0	7 / 8	0,40	750	> 10 ³	45 ± 30	25,9	32,0
10-2421-40070-000	6,0	70,0	10 / 10	0,40	750	> 10 ³	45 ± 30	29,1	36,0
10-2421-40090-000	6,5	93,0	13 / 14	0,40	750	> 10 ³	45 ± 30	34,7	41,0
10-2421-40140-000	8,6	142,0	19 / 20	0,40	750	> 10 ³	45 ± 30	45,3	43,0

SONDERAUSFÜHRUNGEN / SPECIAL CONFIGURATIONS

auf Anfrage
on inquiry