

60-0601... LUFTROHRTRIMMER AIRTUBULAR TRIMMER

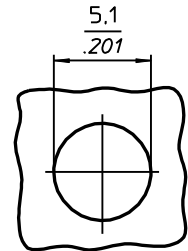

Einbaumaß
 Mounting layout

Zubehör (u.a. auf Anfrage)
 Accessories (a.o. on inquiry)

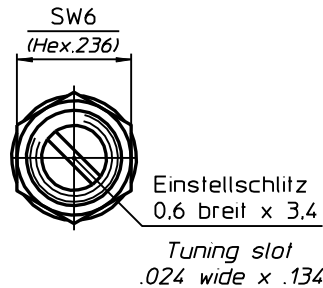
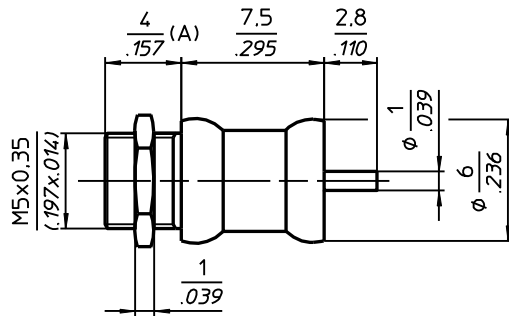
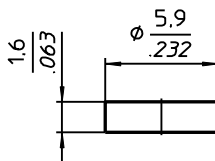

Dichtkappe : Maß A+0,5
 Seal cap : Dim A+.02

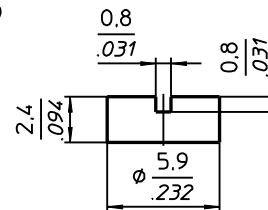

Dichtkappe geschlitzt : Maß A+1,3
 Slotted seal cap : Dim A+.051

TECHNISCHE MERKMALE UND DATEN / TECHNICAL DATA

EINSTELLDREHMOMENT TUNING TORQUE	0,3 - 3,0 Ncm 0.4 - 4.2 in.oz.	LEBENSDAUER ROTATIONAL LIFE	≥ 75 Betätigungen, IEC 418 ≥ 75 cycles, IEC 418
ANSCHLAGDREHMOMENT STOP TORQUE	max. 6,0 Ncm max. 8.3 in.oz.	VIBRATION VIBRATION	60 g / 10 - 2000 Hz 60 g / 10 - 2000 Hz
BEFESTIGUNGSDREHMOMENT MOUNTING TORQUE	max. 30 Ncm max. 42 in.oz.	STOSSBEANSPRUCHUNG SHOCK	1500 g / 0,5 ms 1500 g / 0.5 ms
EINSTELLGENAUIGKEIT ADJUSTMENT ACCURACY	≤ 1 x10 ⁻³ vom Einstellwert ≤ 1 x10 ⁻³ of adjusted value	BETRIEBSTEMPERATUR OPERATING TEMPERATURE	-65°C ... +125°C -65°C ... +125°C
KONTAKTWIDERSTAND CONTACT RESISTANCE	< 0,001 Ω < 0.001 Ω	DIELEKTRIKUM DIELECTRIC	Luft Air

STANDARD - AUSFÜHRUNGEN / STANDARD CONFIGURATIONS

Teile - Nr. Part - No.	C _{min} [pF]	C _{max} [pF]	Prüfspannung Test Voltage [VDC]	Q-Faktor Q-Factor [@ 200MHz]	R _{isol.} R _{insul.} [MΩ]	TK _c [ppm/°C]	Maß A Dim.A [mm]	Maß B Dim.B [mm]	Gewicht Weight [ca. g]
60-0601-10007-000	0,6	7,0	250	> 5000	> 10 ⁶	0 ± 50	4,0	---	1,4

SONDERAUSFÜHRUNGEN (auf Anfrage) / SPECIAL CONFIGURATIONS (on inquiry)

z.B. Trimmer unmagnetisch, verlängerte Welle, Hochtemperatur-Lot u.a.
 e.g. Trimmer non-magnetic, extended shaft, high temperature solder a.o.