

## 60-0741... LUFTRÖHRTRIMMER AIRTUBULAR TRIMMER

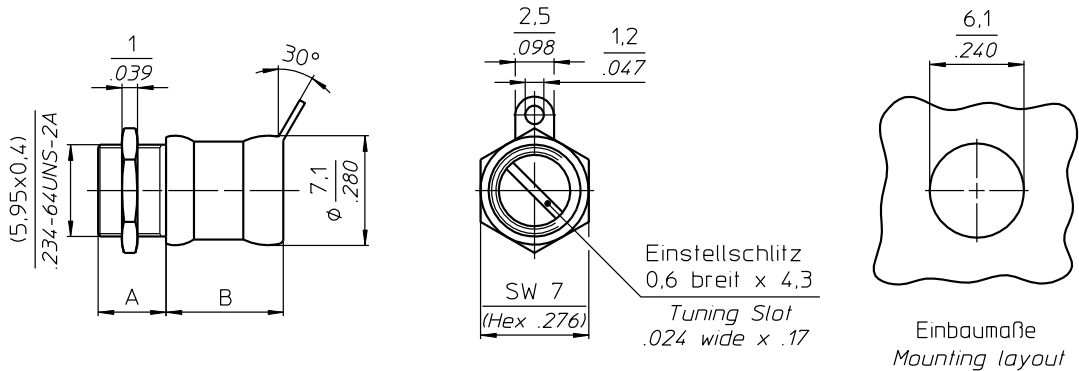

Zubehör (u.a. auf Anfrage)  
 Accessories (a.o. on inquiry)

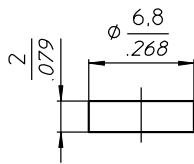

Dichtkappe lose : Maß A +0,5  
 Sealcap unmounted : Dim A +.02

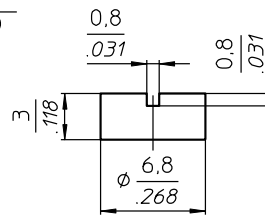

Dichtkappe geschlitzt lose : Maß A +1,4  
 Slotted sealcap unmounted : Dim A +.055

### TECHNISCHE MERKMALE UND DATEN / TECHNICAL DATA

EINSTELLDREHMOMENT <i>TUNING TORQUE</i>	0,7 - 3,6 Ncm <i>0.9 - 5.0 in.oz.</i>	LEBENSDAUER <i>ROTATIONAL LIFE</i>	≥ 75 Betätigungen, IEC 418 <i>≥ 75 cycles, IEC 418</i>
ANSCHLAGDREHMOMENT <i>STOP TORQUE</i>	max. 8,0 Ncm <i>max. 11.1 in.oz.</i>	VIBRATION <i>VIBRATION</i>	60 g / 10 - 2000 Hz <i>60 g / 10 - 2000 Hz</i>
BEFESTIGUNGSDREHMOMENT <i>MOUNTING TORQUE</i>	max. 50 Ncm <i>max. 70 in.oz.</i>	STOSSBEANSPRUCHUNG <i>SHOCK</i>	1500 g / 0,5 ms <i>1500 g / 0.5 ms</i>
EINSTELLGENAUIGKEIT <i>ADJUSTMENT ACCURACY</i>	≤ 1 x10 <sup>-3</sup> vom Einstellwert <i>≤ 1 x10<sup>-3</sup> of adjusted value</i>	BETRIEBSTEMPERATUR <i>OPERATING TEMPERATURE</i>	-65°C ... +125°C <i>-65°C ... +125°C</i>
KONTAKTWIDERSTAND <i>CONTACT RESISTANCE</i>	< 0,001 Ω <i>&lt; 0.001 Ω</i>	DIELEKTRIKUM <i>DIELECTRIC</i>	Luft <i>Air</i>

### STANDARD - AUSFÜHRUNGEN / STANDARD CONFIGURATIONS

Teile - Nr. Part - No.	C <sub>min</sub> [pF]	C <sub>max</sub> [pF]	Prüfspannung Test Voltage [VDC]	Q-Faktor Q-Factor [@ 200MHz]	R <sub>isol.</sub> R <sub>insul.</sub> [MΩ]	TK <sub>c</sub> [ppm/°C]	Maß A Dim.A [mm]	Maß B Dim.B [mm]	Gewicht Weight [ca. g]
60-0741-15010-000	0,8	10,0	500	> 5000	> 10 <sup>6</sup>	0 ± 15	4,4	7,5	1,9
60-0741-15014-000	1,0	14,0	300	> 5000	> 10 <sup>6</sup>	0 ± 15	4,4	7,5	2,1
60-0741-15020-000	1,0	20,0	300	> 1000	> 10 <sup>6</sup>	30 ± 20	5,9	12,5	2,9
60-0741-15025-000	1,0	25,0	300	> 1000	> 10 <sup>6</sup>	50 ± 50	5,9	12,5	3,1
60-0741-15030-000	1,0	30,0	300	> 500	> 10 <sup>6</sup>	30 ± 20	6,8	16,7	3,6

### SONDERAUSFÜHRUNGEN (auf Anfrage) / SPECIAL CONFIGURATIONS (on inquiry)

z.B. Trimmer unmagnetisch, verlängerte Welle, Hochtemperatur-Lot u.a.  
 e.g. *Trimmer non-magnetic, extended shaft, high temperature solder a.o.*