

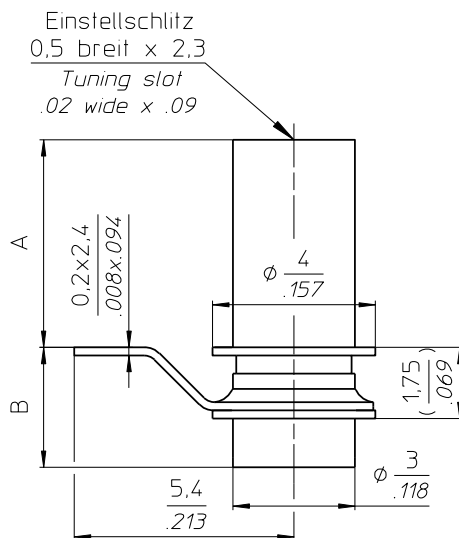

66-0314... SAPHIRTRIMMER SAPPHIRE TRIMMER

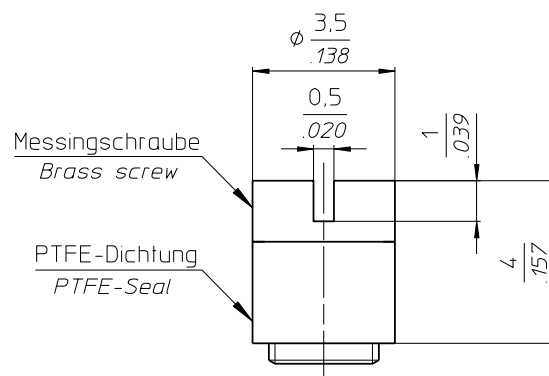

Zubehör / Accessories



mehrmals verwendbare Montage-Dichtschaube
Seal cap suitable for repeated usage

TECHNISCHE MERKMALE UND DATEN / TECHNICAL DATA

EINSTELLDREHMOMENT TUNING TORQUE	0,1 - 1,0 Ncm 0.14 - 1.4 in.oz.	LEBENSDAUER ROTATIONAL LIFE	≥ 75 Betätigungen, IEC 418 ≥ 75 cycles, IEC 418
ANSCHLAGDREHMOMENT STOP TORQUE	max. 1,5 Ncm max. 2.1 in.oz.	VIBRATION VIBRATION	60 g / 10 - 2000 Hz 60 g / 10 - 2000 Hz
BEFESTIGUNGSDREHMOMENT MOUNTING TORQUE	---	STOSSBEANSPRUCHUNG SHOCK	1500 g / 0,5 ms 1500 g / 0.5 ms
EINSTELLGENAUIGKEIT ADJUSTMENT ACCURACY	≤ 1 x10 ⁻³ vom Einstellwert ≤ 1 x10 ⁻³ of adjusted value	BETRIEBSTEMPERATUR OPERATING TEMPERATURE	-65°C ... +125°C -65°C ... +125°C
KONTAKTWIDERSTAND CONTACT RESISTANCE	< 0,001 Ω < 0.001 Ω	DIELEKTRIKUM DIELECTRIC	Saphir Sapphire

STANDARD - AUSFÜHRUNGEN / STANDARD CONFIGURATIONS

Teile - Nr. Part - No.	C _{min} [pF]	C _{max} [pF]	Prüfspannung Test Voltage [VDC]	Q-Faktor Q-Factor [@ 200MHz]	R _{isol.} R _{insul.} [MΩ]	TK _c [ppm / °C]	Maß A Dim.A [mm]	Maß B Dim.B [mm]	Gewicht Weight [ca. g]
66-0314-00002-000	0,4	2,5	1000	> 4000	> 10 ⁶	0 ± 50	3,7	2,1	0,33
66-0314-00004-000	0,6	4,5	1000	> 3000	> 10 ⁶	0 ± 50	5,1	2,9	0,41
66-0314-00008-000	0,8	8,0	1000	> 2000	> 10 ⁶	0 ± 75	7,1	5,2	0,56

SONDERAUSFÜHRUNGEN / SPECIAL CONFIGURATIONS

z.B. Trimmer unmagnetisch (Permeabilität < 1,001), verlängerte Welle u.a. auf Anfrage
e.g. Trimmer non-magnetic (permeability < 1,001), extended shaft a.o. on inquiry