

66-0317...
SAPHIRTRIMMER
SAPPHIRE TRIMMER

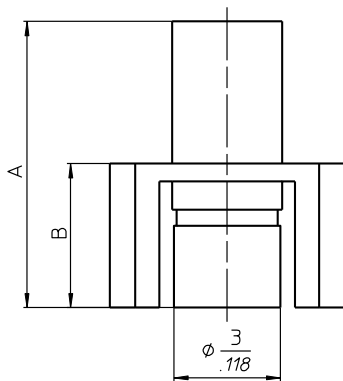

Zubehör / Accessories

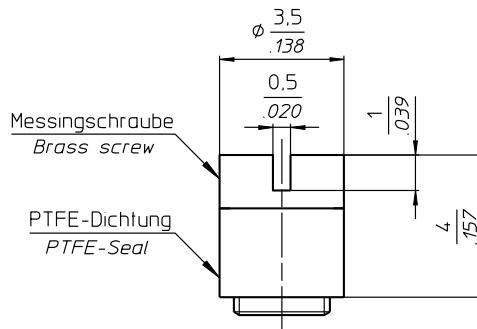

mehrmals verwendbare Montage-Dichtschraube
Seal cap suitable for repeated usage

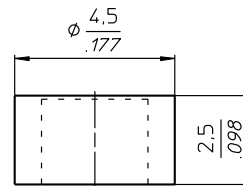
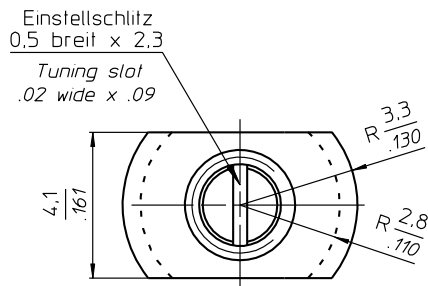

durchstoßbare PTFE-Dichtkappe
penetrable PTFE-seal cap

TECHNISCHE MERKMALE UND DATEN / TECHNICAL DATA

EINSTELLDREHMOMENT <i>TUNING TORQUE</i>	0,1 - 1,0 Ncm <i>0.14 - 1.4 in.oz.</i>	LEBENSDAUER <i>ROTATIONAL LIFE</i>	≥ 75 Betätigungen, IEC 418 <i>≥ 75 cycles, IEC 418</i>
ANSCHLAGDREHMOMENT <i>STOP TORQUE</i>	max. 1,5 Ncm <i>max. 2.1 in.oz.</i>	VIBRATION <i>VIBRATION</i>	60 g / 10 - 2000 Hz <i>60 g / 10 - 2000 Hz</i>
BEFESTIGUNGSDREHMOMENT <i>MOUNTING TORQUE</i>	---	STOSSBEANSPRUCHUNG <i>SHOCK</i>	1500 g / 0,5 ms <i>1500 g / 0.5 ms</i>
EINSTELLGENAUIGKEIT <i>ADJUSTMENT ACCURACY</i>	≤ 1 x 10 ⁻³ vom Einstellwert <i>≤ 1 x 10⁻³ of adjusted value</i>	BETRIEBSTEMPERATUR <i>OPERATING TEMPERATURE</i>	-65°C ... +125°C <i>-65°C ... +125°C</i>
KONTAKTWIDERSTAND <i>CONTACT RESISTANCE</i>	< 0,001 Ω <i>< 0.001 Ω</i>	DIELEKTRIKUM <i>DIELECTRIC</i>	Saphir <i>Sapphire</i>

STANDARD - AUSFÜHRUNGEN / STANDARD CONFIGURATIONS

Teile - Nr. <i>Part - No.</i>	C _{min} [pF]	C _{max} [pF]	Prüfspannung <i>Test Voltage</i> [VDC]	Q-Faktor <i>Q-Factor</i> [@ 200MHz]	R _{isol.} <i>R_{insul.}</i> [MΩ]	TK _c [ppm / °C]	Maß A <i>Dim.A</i> [mm]	Maß B <i>Dim.B</i> [mm]	Gewicht <i>Weight</i> [ca. g]
66-0317-00002-000	0,45	2,5	1000	> 4000	> 10 ⁶	0 ± 50	5,8	3,2	0,4
66-0317-00004-000	0,65	4,5	1000	> 3000	> 10 ⁶	0 ± 50	8,0	4,2	0,5
66-0317-00008-000	0,85	8,0	1000	> 2000	> 10 ⁶	0 ± 75	12,3	6,5	0,6

SONDERAUSFÜHRUNGEN / SPECIAL CONFIGURATIONS

z.B. Trimmer unmagnetisch (Permeabilität < 1,001), Trimmer gegurtert, verlängerte Welle u.a. auf Anfrage
e.g. Trimmer non-magnetic (permeability < 1,001), Trimmer on tape & reel, extended shaft a.o. on inquiry