

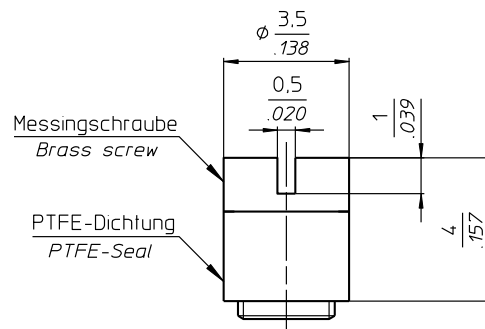

## 66-03.7... SAPHIRTRIMMER SAPPHIRE TRIMMER

### Zubehör / Accessories

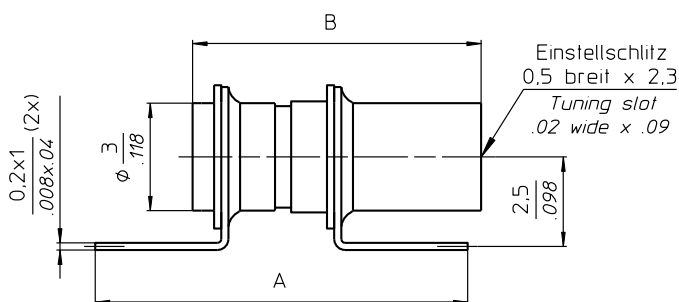

mehrmals verwendbare Montage-Dichtschaube  
Seal cap suitable for repeated usage

### TECHNISCHE MERKMALE UND DATEN / TECHNICAL DATA

EINSTELLDREHMOMENT TUNING TORQUE	0,1 - 1,0 Ncm 0.14 - 1.4 in.oz.	LEBENSDAUER ROTATIONAL LIFE	≥ 75 Betätigungen, IEC 418 ≥ 75 cycles, IEC 418
ANSCHLAGDREHMOMENT STOP TORQUE	max. 1,5 Ncm max. 2.1 in.oz.	VIBRATION VIBRATION	60 g / 10 - 2000 Hz 60 g / 10 - 2000 Hz
BEFESTIGUNGSDREHMOMENT MOUNTING TORQUE	---	STOSSBEANSPRUCHUNG SHOCK	1500 g / 0,5 ms 1500 g / 0.5 ms
EINSTELLGENAUIGKEIT ADJUSTMENT ACCURACY	≤ 1 x10 <sup>-3</sup> vom Einstellwert ≤ 1 x10 <sup>-3</sup> of adjusted value	BETRIEBSTEMPERATUR OPERATING TEMPERATURE	-65°C ... +125°C -65°C ... +125°C
KONTAKTWIDERSTAND CONTACT RESISTANCE	< 0,001 Ω < 0.001 Ω	DIELEKTRIKUM DIELECTRIC	Saphir Sapphire

### STANDARD - AUSFÜHRUNGEN / STANDARD CONFIGURATIONS

Teile - Nr. Part - No.	C <sub>min</sub> [pF]	C <sub>max</sub> [pF]	Prüfspannung Test Voltage [VDC]	Q-Faktor Q-Factor [@ 200MHz]	R <sub>isol.</sub> R <sub>insul.</sub> [MΩ]	TK <sub>c</sub> [ppm / °C]	Maß A Dim.A [mm]	Maß B Dim.B [mm]	Gewicht Weight [ca. g]
66-0307-00002-000	0,4	2,5	1000	> 4000	> 10 <sup>6</sup>	0 ± 50	9,2	5,8	0,31
66-0307-00004-000	0,6	4,5	1000	> 3000	> 10 <sup>6</sup>	0 ± 50	10,4	8,0	0,39
66-0307-00008-000	0,8	8,0	1000	> 2000	> 10 <sup>6</sup>	0 ± 75	13,8	12,3	0,53
66-0337-00002-000	0,4	2,5	1000	> 4000	> 10 <sup>6</sup>	350 ± 75	9,2	5,8	0,31
66-0337-00004-000	0,6	4,5	1000	> 3000	> 10 <sup>6</sup>	350 ± 75	10,4	8,0	0,39
66-0337-00008-000	0,8	8,0	1000	> 2000	> 10 <sup>6</sup>	350 ± 75	13,8	12,3	0,53

### SONDERAUSFÜHRUNGEN / SPECIAL CONFIGURATIONS

z.B. Trimmer unmagnetisch (Permeabilität < 1,001), verlängerte Welle u.a. auf Anfrage  
e.g. Trimmer non-magnetic (Permeability < 1,001), extended shaft a.o. on inquiry