

**62-0307-00010-000**  
 ZIRKONIATRIMMER  
 ZIRCONIA TRIMMER

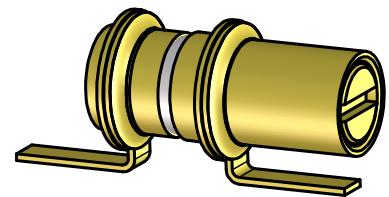
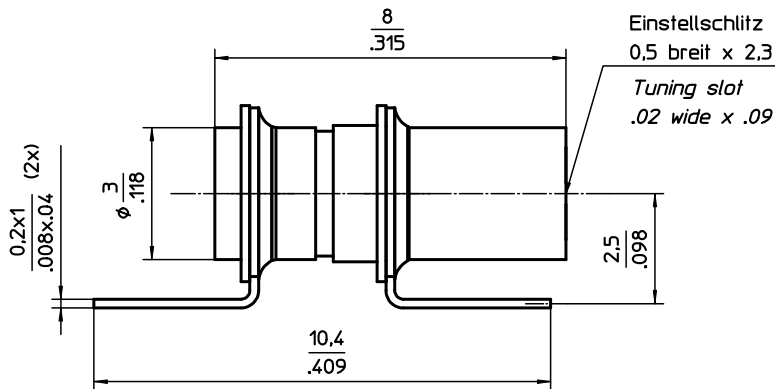

**TECHNISCHE MERKMALE UND DATEN / TECHNICAL DATA**

EINSTELLDREHMOMENT <i>TUNING TORQUE</i>	0,1 – 1,0 Ncm <i>0.14 - 1.4 in.oz.</i>	LEBENSDAUER <i>ROTATIONAL LIFE</i>	≥ 75 Betätigungen, IEC 418 <i>≥ 75 cycles, IEC 418</i>
ANSCHLAGDREHMOMENT <i>STOP TORQUE</i>	max. 1,5 Ncm <i>max. 2.1 in.oz.</i>	VIBRATION <i>VIBRATION</i>	60 g / 10 - 2000 Hz <i>60 g / 10 - 2000 Hz</i>
BEFESTIGUNGSDREHMOMENT <i>MOUNTING TORQUE</i>	---	STOSSBEANSPRUCHUNG <i>SHOCK</i>	1500 g / 0,5 ms <i>1500 g / 0.5 ms</i>
EINSTELLGENAUGIGKEIT <i>ADJUSTMENT ACCURACY</i>	≤ 1 x10 <sup>-3</sup> vom Einstellwert <i>≤ 1 x10<sup>-3</sup> of adjusted value</i>	BETRIEBSTEMPERATUR <i>OPERATING TEMPERATURE</i>	-65°C ... +125 °C <i>-65°C ... +125°C</i>
KONTAKTWIDERSTAND <i>CONTACT RESISTANCE</i>	< 0,001 Ω <i>&lt; 0.001 Ω</i>	DIELEKTRIKUM <i>DIELECTRIC</i>	Zirkon <i>Zirconia</i>

**STANDARD - AUSFÜHRUNGEN / STANDARD CONFIGURATIONS**

Teile - Nr. <i>Part - No.</i>	C <sub>min</sub> [pF]	C <sub>max</sub> [pF]	Prüfspannung <i>Test Voltage</i> [VDC]	Q-Faktor <i>Q-Factor</i> [@ 200MHz]	R <sub>isol.</sub> <i>R<sub>insul.</sub></i> [MΩ]	TK <sub>c</sub> [ppm / °C]	Maß A <i>Dim.A</i> [mm]	Maß B <i>Dim.B</i> [mm]	Gewicht <i>Weight</i> [ca. g]
62-0307-00010-000	1,0	10,0	1000	> 3000	> 10 <sup>6</sup>	0 ± 50	---	---	0,39

**SONDERANFERTIGUNG / SPECIAL CONFIGURATION**

z.B. Trimmer unmagnetisch (Permeabilität < 1,001), Trimmer gegurtert u.a. auf Anfrage  
 e.g. *Trimmer non-magnetic (Permeability < 1,001), trimmer on tape & reel a.o. on inquiry*